

CONECTOR BASE MR16 CON CABLE

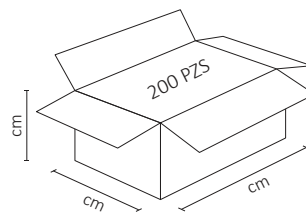

Ideal para conectar MR16 en conexiones de tipo GU5.3.

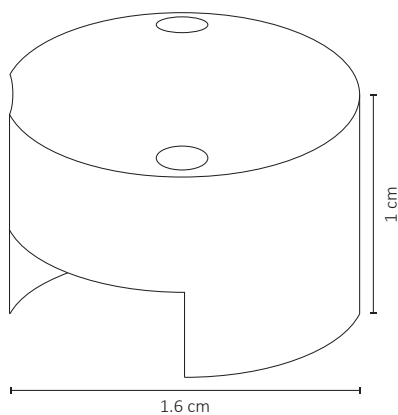

ESPECIFICACIONES

#	WAC-005
	ACCESORIO
W	100 WATTS
	90-300V ~ 50/60 Hz
	N/A
	N/A
360°	N/A
	N/A
	N/A
	N/A
KH	16x10mm
	PESO: 10gr.
	PLÁSTICO
	ATENUABLE: N/A
	OPERACIÓN: -10 A 40°C
	IP20

VIDA ÚTIL: 30,000

