



LÍNEA
ALX



LÍNEA
STX

CATÁLOGO
2020

Hannover
Lighting



LÍNEA ALX ALL IN ONE

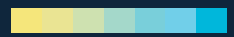

Hannover
Lighting

180
LM/W
EFICIENCIA



12hrs
DE USO
CONTINUO
DIARIO

Luminario TODO EN UNO con sistema autónomo, listo para usarse. Incluye sensor de luz, control inteligente, panel solar, LED con óptica, en PC de alta eficiencia, respaldo de baterías de última generación.



LUMINARIO LED SOLAR ALL IN ONE

Código: **ALX-20W**

180
LM/W
EFICIENCIA

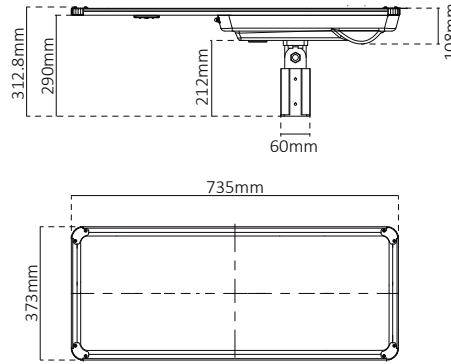

VIDA ÚTIL LED: 100,000Hrs.

PHILIPS
LUMILEDS

| | |
|--|---------------------------------|
| | Panel Monocristalino |
| | 18V 40Wp |
| | 20W |
| | LiFePO ₄ 12.8V @12Ah |
| | Tiempo de Carga: 6 Horas |
| | 3,600Lm |
| | Días Nublados: 2-3 Días |
| | Tipo II-M Max. 140° |
| | 3000K/4000K/5700K |
| | IRC - REND. COLOR > 70 |
| | 28 LEDs Philips 5050 |
| | 735x373x108mm |
| | Peso: 7kg. |
| | PC+Aluminio |
| | Operación: -20 A 60°C |
| | IP66 |
| | IK09 |

Código: **ALX-30W**

LUMINARIO LED SOLAR ALL IN ONE

180
LM/W
EFICIENCIA

| | |
|--|---------------------------------|
| | Panel Monocristalino |
| | 18V 50Wp |
| | 30W |
| | LiFePO ₄ 12.8V @18Ah |
| | Tiempo de Carga: 6 Horas |
| | 5,400Lm |
| | Días Nublados: 2-3 Días |
| | Tipo II-M Max. 140° |
| | 3000K/4000K/5700K |
| | IRC - REND. COLOR > 70 |
| | 28 LEDs Philips 5050 |
| | 880x373x108mm |
| | Peso: 9kg. |
| | PC+Aluminio |
| | Operación: -20 A 60°C |
| | IP66 |
| | IK09 |

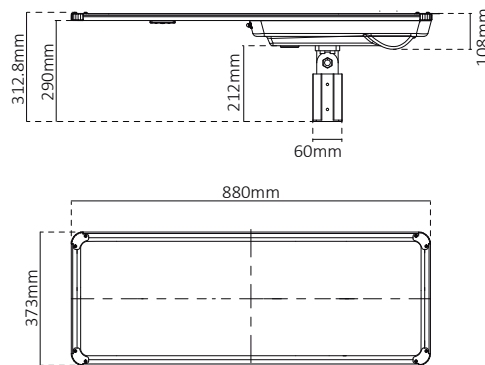

VIDA ÚTIL LED: 100,000Hrs.

PHILIPS
LUMILEDS



Hannover
Lighting

Código: **ALX-40W**

LUMINARIO LED SOLAR ALL IN ONE

| | |
|--|---------------------------------|
|  | Panel Monocristalino |
|  | 18V 50Wp |
|  | 40W |
|  | LiFePO ₄ 12.8V @30Ah |
|  | Tiempo de Carga: 6 Horas |
|  | 7,200Lm |
|  | Días Nublados: 2-3 Días |
|  | Tipo II-M Max. 140° |
|  | 3000K/4000K/5700K |
|  | IRC - REND. COLOR > 70 |
|  | 28 LEDs Philips 5050 |
|  | 880x373x108mm |
|  | Peso: 13kg. |
|  | PC+Aluminio |
|  | Operación: -20 A 60°C |
|  | IP66 |
|  | IK09 |

180
LM/W
EFICIENCIA

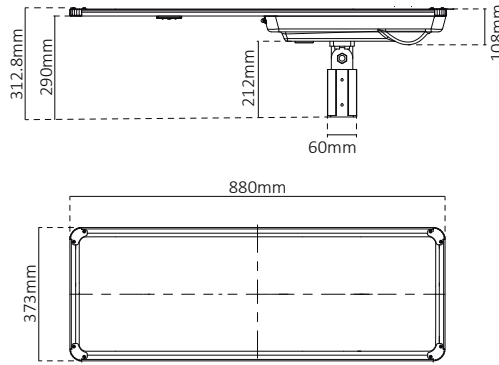

VIDA ÚTIL LED: 100,000Hrs.

PHILIPS
LUMILEDS



LUMINARIO LED SOLAR ALL IN ONE

Código: **ALX-50W**

180
LM/W
EFICIENCIA

| | |
|---|---------------------------------|
|  | Panel Monocristalino |
|  | 18V 60Wp |
|  | 50W |
|  | LiFePO ₄ 12.8V @18Ah |
|  | Tiempo de Carga: 6 Horas |
|  | 9,000Lm |
|  | Días Nublados: 3-2 Días |
|  | Tipo II-M Max. 140° |
|  | 3000K/4000K/5700K |
|  | IRC - REND. COLOR > 70 |
|  | 28 LEDs Philips 5050 |
|  | 988x373x108mm |
|  | Peso: 16kg. |
|  | PC+Aluminio |
|  | Operación: -20 A 60°C |
|  | IP66 |
|  | IK09 |

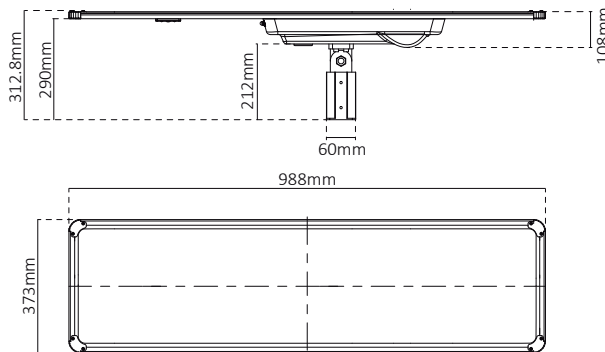

VIDA ÚTIL LED: 100,000Hrs.

PHILIPS
LUMILEDS

Hannover
Lighting

LUMINARIO LED SOLAR ALL IN ONE

Código: **ALX-60W**

180
LM/W
EFICIENCIA



VIDA ÚTIL LED: 100,000Hrs.

PHILIPS
LUMILEDS

| | |
|--|---------------------------------|
| | Panel Monocristalino |
| | 18V 80Wp |
| | 60W |
| | LiFePO ₄ 12.8V @36Ah |
| | Tiempo de Carga: 6 Horas |
| | 10,800Lm |
| | Días Nublados: 2-3 Días |
| | Tipo II-M Max. 140° |
| | 3000K/4000K/5700K |
| | IRC - REND. COLOR > 70 |
| | 56 LEDs Philips 5050 |
| | 988x373x108mm |
| | Peso: 18kg. |
| | PC+Aluminio |
| | Operación: -20 A 60°C |
| | IP66 |
| | IK09 |

Código: **ALX-80W**

LUMINARIO LED SOLAR ALL IN ONE

175
LM/W
EFICIENCIA

| | |
|--|---------------------------------|
| | Panel Monocristalino |
| | 18V 100Wp |
| | 80W |
| | LiFePO ₄ 12.8V @42Ah |
| | Tiempo de Carga: 6 Horas |
| | 14,000Lm |
| | Días Nublados: 2-3 Días |
| | Tipo II-M Max. 140° |
| | 3000K/4000K/5700K |
| | IRC - REND. COLOR > 70 |
| | 56 LEDs Philips 5050 |
| | 1482x373x108mm |
| | Peso: 20kg. |
| | PC+Aluminio |
| | Operación: -20 A 60°C |
| | IP66 |
| | IK09 |

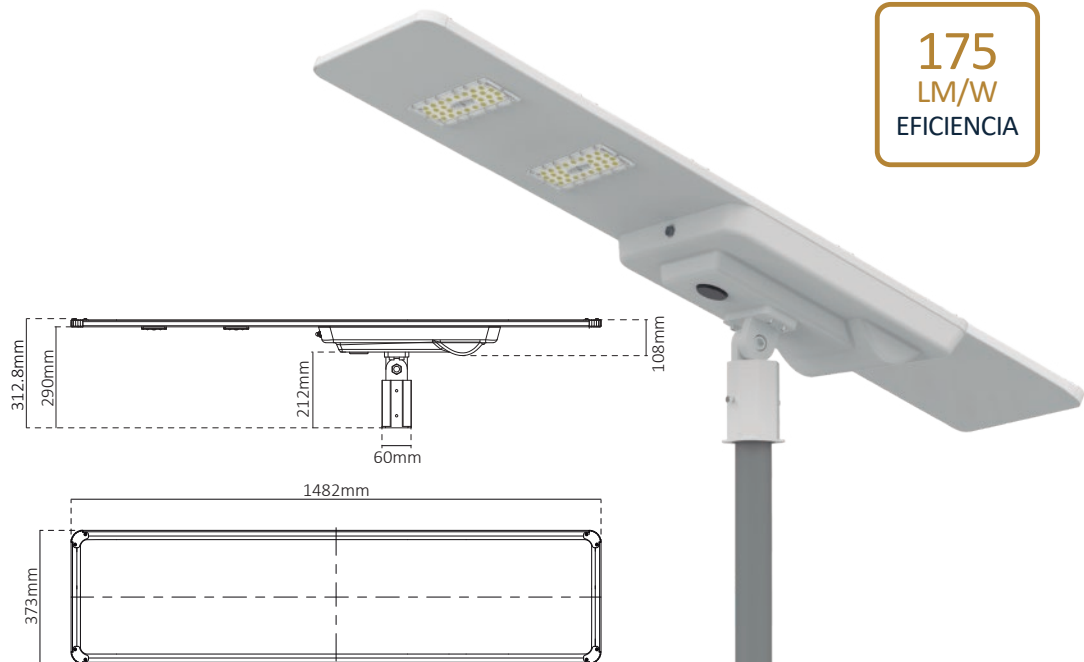

VIDA ÚTIL LED: 100,000Hrs.

PHILIPS
LUMILEDS

Hannover
Lighting

CARACTERÍSTICAS

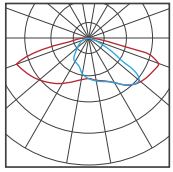

ÁNGULO DE APERTURA

Adecuado para vialidades como: estacionamientos, calles, avenidas, andadores, etc.

Type II-M(A)

Max 140°

ÓPTICA



SISTEMA DE SENSOR DE MOVIMIENTO

Detecta cuando una persona pasa y se intensifica su potencia de luz, de un 20% a un 100%.

Cuando la iluminación es inferior a 100lx, comienza a funcionar. 12 horas de uso continuo diario.

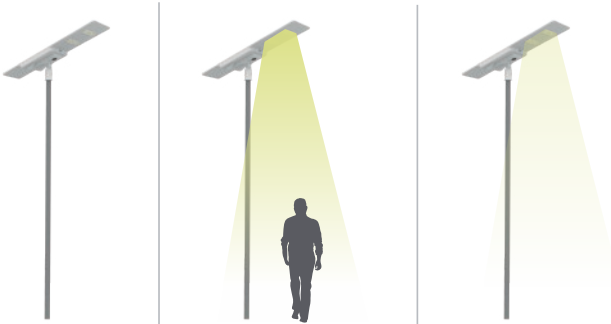

| Tiempo de Inicio | Alguien Bajo la Luz en la Noche | Nadie Bajo la Luz en la Noche |
|------------------|---------------------------------|-------------------------------|
| 2H | 100% | 30% |
| 3H | 50% | 20% |
| 6H | 20% | 10% |
| 1H | 30% | 10% |

PRINCIPIO DE FUNCIONAMIENTO

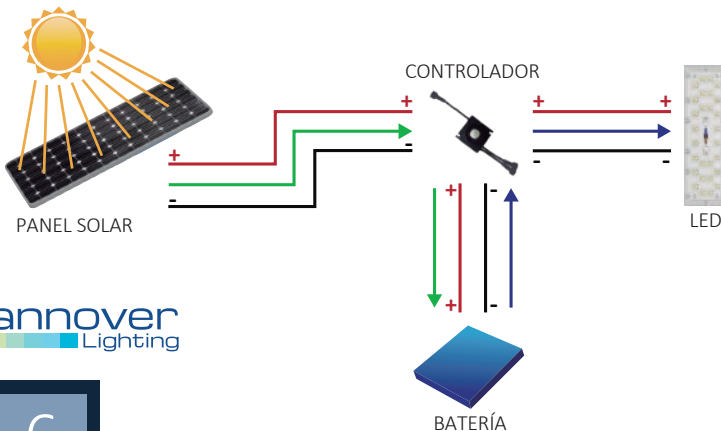

PANEL SOLAR MONOCRISTALINO



A prueba de agua IP66. Conversión fotoeléctrica estable y eficiente. Tecnología difusa avanzada, que puede garantizar la uniformidad de la eficiencia de conversión.

El panel monocristalino de alta eficiencia permite un índice de conversión de 19.9%, que se aprovecha a su vez con células de batería de grado A1 26650.

BATERÍA

Batería de fosfato de hierro y litio. El controlador inteligente coincide con el sensor de microondas o infrarrojos inteligentes PIR para asegurar el tiempo de iluminación efectiva.

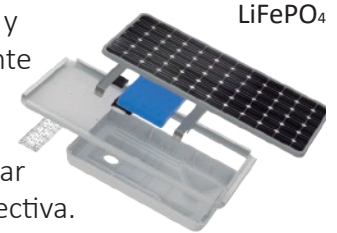

ROTACIÓN 360°

El brazo se puede ajustar en muchos ángulos, de acuerdo con los requisitos de instalación.



A PRUEBA DE CLIMAS EXTREMOS

Resiste Vientos de hasta 233 km/h



LÍNEA STX PARA CALLE



Hannover
Lighting



DE 145
HASTA 155
LM/W
EFICIENCIA

Las luminarias para calle STX de diseño alemán se idearon para reemplazar tecnologías obsoletas en economías emergentes, integrando un concepto innovador y proveedores de Estados Unidos (LED PHILIPS LUMILED 3030) y otros países.

Código: **STX-40W**

LUMINARIO PHILIPS LUMILEDS 3030 PARA LA CALLE



Luminaria LED para Calle



40W



100-277V CA 50/60Hz



FP > 0.98



6,200Lm



145x45°



3000K/4000K/5700K



IRC - REND. COLOR > 80



Philips Lumiled 3030



525x255x112mm



Peso: 3.2kg.



PC+Aluminio



Atenuable: NO



Operación: -10 A 50°C



IP65

155
LM/W
EFICIENCIA

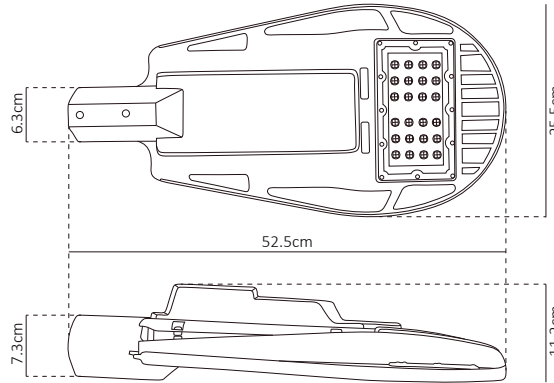

VIDA ÚTIL LED: 100,000Hrs.

PHILIPS
LUMILEDS

LUMINARIO PHILIPS LUMILEDS 3030 PARA LA CALLE

Código: **STX-50W**

150
LM/W
EFICIENCIA



Luminaria LED para Calle



50W



100-277V CA 50/60Hz



FP > 0.98



7,500Lm



145x45°



3000K/4000K/5700K



IRC - REND. COLOR > 80



Philips Lumiled 3030



525x255x112mm



Peso: 3.2kg.



PC+Aluminio



Atenuable: NO



Operación: -10 A 50°C



IP65

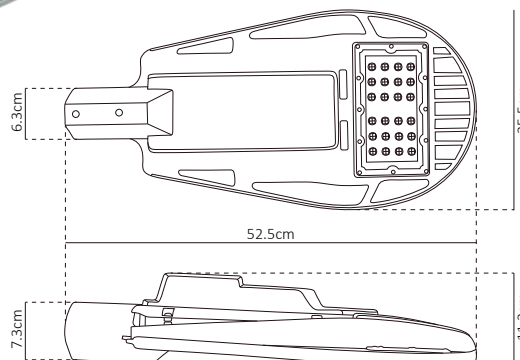

VIDA ÚTIL LED: 100,000Hrs.

PHILIPS
LUMILEDS

LUMINARIO PHILIPS LUMILEDS 3030 PARA LA CALLE

Código: **STX-60W**

145
LM/W
EFICIENCIA

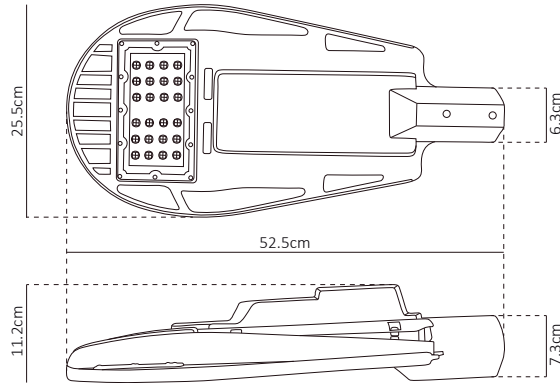

VIDA ÚTIL LED: 100,000Hrs.

PHILIPS
LUMILEDS

- Luminaria LED para Calle
- W** 60W
- 100-277V CA 50/60Hz
- FP > 0.98
- 8,700Lm
- 360°** 145x45°
- 3000K/4000K/5700K
- IRC - REND. COLOR > 80
- Philips Lumiled 3030
- 525x255x112mm**
- Gramos** Peso: 3.2kg.
- PC+Aluminio
- Atenuable: NO
- Operación: -10 A 50°C
- IP65

Código: **STX-80W**

LUMINARIO PHILIPS LUMILEDS 3030 PARA LA CALLE

- Luminaria LED para Calle
- W** 80W
- 100-277V CA 50/60Hz
- FP > 0.98
- 12,400Lm
- 360°** 145x45°
- 3000K/4000K/5700K
- IRC - REND. COLOR > 80
- Philips Lumiled 3030
- 620x270x115mm**
- Gramos** Peso: 4kg.
- PC+Aluminio
- Atenuable: NO
- Operación: -10 A 50°C
- IP65

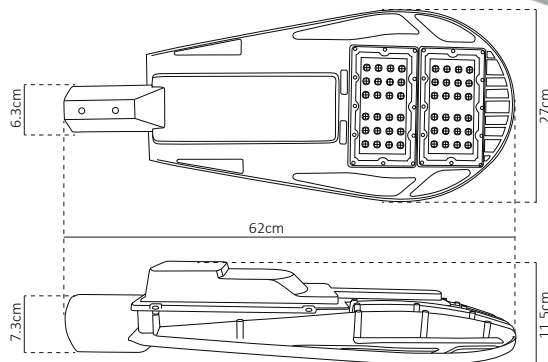

VIDA ÚTIL LED: 100,000Hrs.

PHILIPS
LUMILEDS

155
LM/W
EFICIENCIA

Hannover
Lighting

LUMINARIO PHILIPS LUMILEDS 3030 PARA LA CALLE

Código: **SLX-100W**

| | |
|---|--------------------------|
|  | Luminaria LED para Calle |
|  | 100W |
|  | 100-277V CA 50/60Hz |
|  | FP > 0.98 |
|  | 15,000Lm |
|  | 145x45° |
|  | 3000K/4000K/5700K |
|  | IRC - REND. COLOR > 80 |
|  | Philips Lumiled 3030 |
|  | 620x270x115mm |
|  | Peso: 4kg. |
|  | PC+Aluminio |
|  | Atenuable: NO |
|  | Operación: -10 A 50°C |
|  | IP65 |

150
LM/W
EFICIENCIA

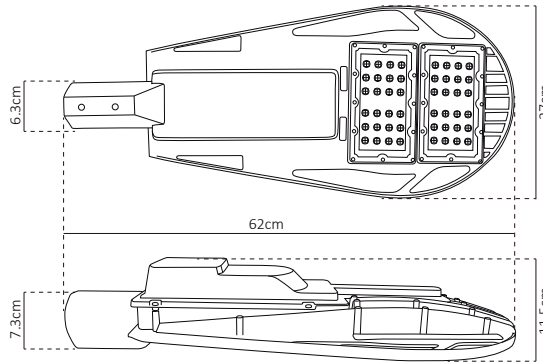

VIDA ÚTIL LED: 100,000Hrs.

PHILIPS
LUMILEDS

Código: **STX-120W**





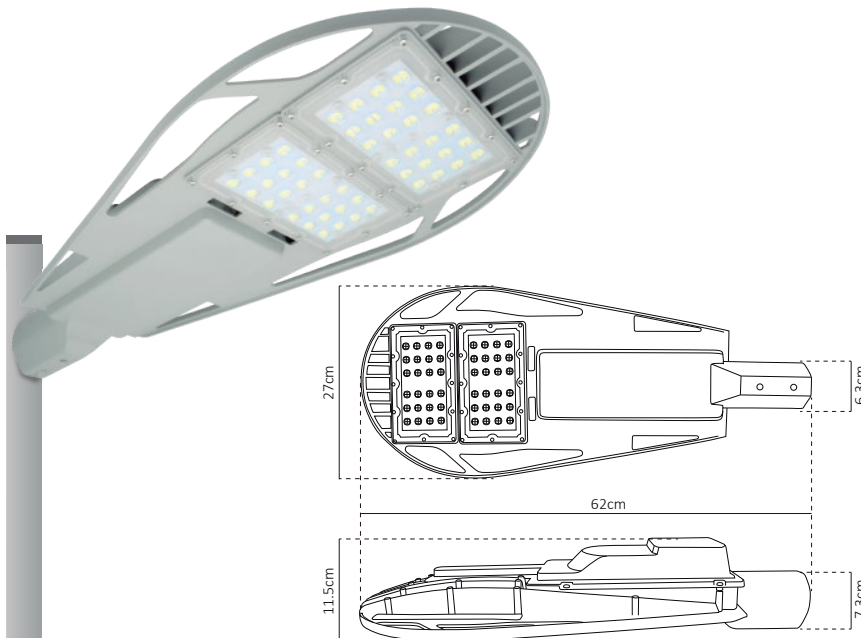









LUMINARIO PHILIPS LUMILEDS 3030 PARA LA CALLE

145
LM/W
EFICIENCIA



VIDA ÚTIL LED: 100,000Hrs.

PHILIPS
LUMILEDS

| | |
|---|--------------------------|
|  | Luminaria LED para Calle |
|  | 120W |
|  | 100-277V CA 50/60Hz |
|  | FP > 0.98 |
|  | 17,400Lm |
|  | 145x45° |
|  | 3000K/4000K/5700K |
|  | IRC - REND. COLOR > 80 |
|  | Philips Lumiled 3030 |
|  | 620x270x115mm |
|  | Peso: 4kg. |
|  | PC+Aluminio |
|  | Atenuable: NO |
|  | Operación: -10 A 50°C |
|  | IP65 |

LUMINARIO PHILIPS LUMILEDS 3030

CARACTERÍSTICAS

PARA LA CALLE



DRIVER
MOSO

MOSO Power ofrece soluciones de iluminación LED para exteriores de alta calidad y rentabilidad.

Ⓜ 30-60W

⚡ 100-240VCA 50/60Hz

@ 0.36-1.80A

↔ 164x64x39mm

🌡 Operación: -10 A 50°C

💧 IP67

ÁNGULOS DE APERTURA

Adecuado para vialidades como: estacionamientos, calles, avenidas, andadores, etc.

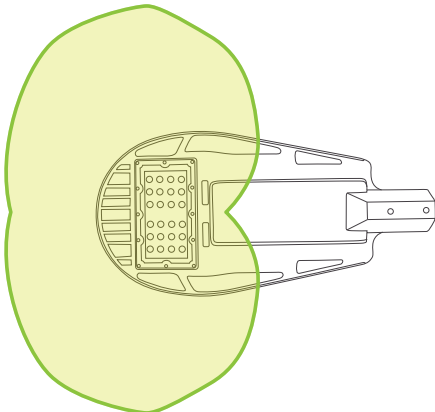
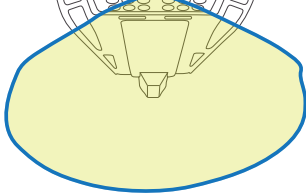
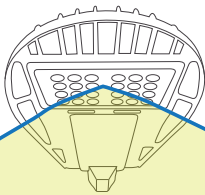
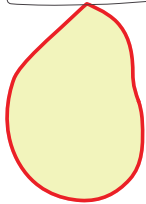
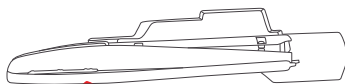

PHILIPS LUMILEDS 3030

Único LED de potencia alta del sector, que garantiza el rendimiento dentro de las especificaciones a temperaturas de operación reales.

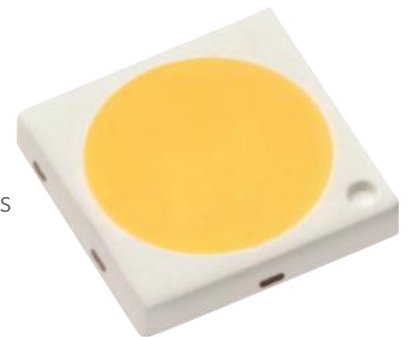

SUPRESOR DE PICOS
MOSO

Evita que los picos de energía causados por las tormentas y subidas de tensión eléctrica llegue a su equipo electrónico.

Hamnover Lighting

